



BÖCKELT TOWER®

Flexible storage and logistics systems

modular reliable cost-efficient



FLEXIBLE STORAGE AND LOGISTICS SYSTEMS



WHICH CONCEPT DO YOU PURSUE?

Since we want you to retain your competitiveness in today's world where streamlining is key and industrial progress advances at break-neck speed, we offer you concepts that are tailored to your specific needs and designed to optimise your flow of material.

Every aspect of our robust and reliable systems has been engineered with the most careful attention to detail in an effort to deliver the performance you expect in your day-to-day operations. Allowing for rapid swaps of material, our systems cut down tooling and non-productive times and increase the machine uptime significantly.

When combined with managing software and a transponder system, our solution turns into an intelligent storage and logistics system that will allow you to stay in full control of your inventory items and their location at all times.

Boasting a modular design, the BÖCKELT TOWER® will grow with the challenges you are faced with in your business. Our partnership with formidable partners has enabled us to expand the systems into fully automated solutions if requirements demand it.



Cassette rack 04



Inventory management 10



Link to machinery 12



Driverless transport systems 13

STORAGE SYSTEMS

DEGREE OF AUTOMATION

COMPREHENSIVE CONCEPTS

Long goods rack 06



Exchange tower 08



Transponder system 11



Stacking crane 13



THE CASSETTE RACK

"THE BÖCKELT TOWER ALLOWS US TO USE OUR WORKING HOURS WITH MUCH GREATER EFFICIENCY AND CUT DOWN OUR COST SIGNIFICANTLY."

Andreas Schmitt,
Schmitt Metal Processing

The rack is loaded and unloaded using a forklift truck. Delivers an exceptional degree of reliability at comparatively low investment costs.

Taking up only minimal space, self-supporting system cassettes are used in the Böckelt Tower® and for in-house transport purposes.

When combined with software and a transponder system, the system can be turned into a dynamic inventory management solution.

"WE WERE PRESENTED WITH CONVINCING CONCEPTS AS EARLY AS THE TENDER STAGE."

Horst Heider,
MTT GmbH



"WE HAVE BEEN USING THE SYSTEM FOR 10 YEARS WITHOUT EXPERIENCING A SINGLE HITCH."

Günter Hommel,
Hommel Metal Spinning

- planned to individual requirements
- solid construction
- enhanced productivity
- Vast storage capacity
- Round-the-clock monitoring of material
- Swift swap of material
- improved on-the-job safety
- reduced damage to material
- effortless removal of material from the cassettes
- low investment costs through use of conventional forklifts

"BETTER STILL, THE BÖCKELT TOWER AFFORDS US FOUR TIMES AS MUCH STORAGE CAPACITY IN THE SAME AMOUNT OF SPACE."

Ingolf Kellner,
ILZ GmbH

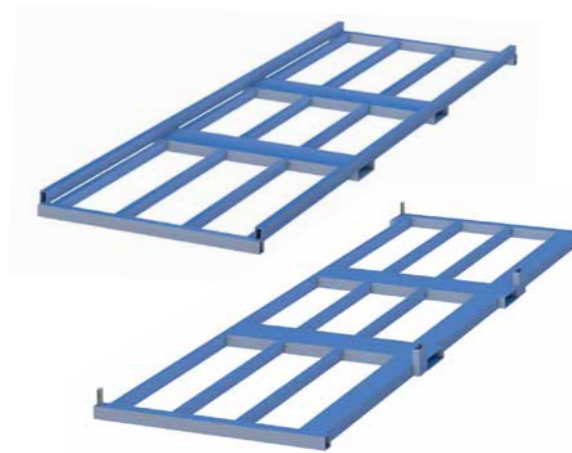

System cassettes



Cassette trolley

"THE MODULAR DESIGN MAKES IT POSSIBLE FOR US TO CONVERT OUR ENTIRE WAREHOUSE ONE STEP AT A TIME."

Mario Marx,
New Laser SPRL

Operating mode of a depalletiser

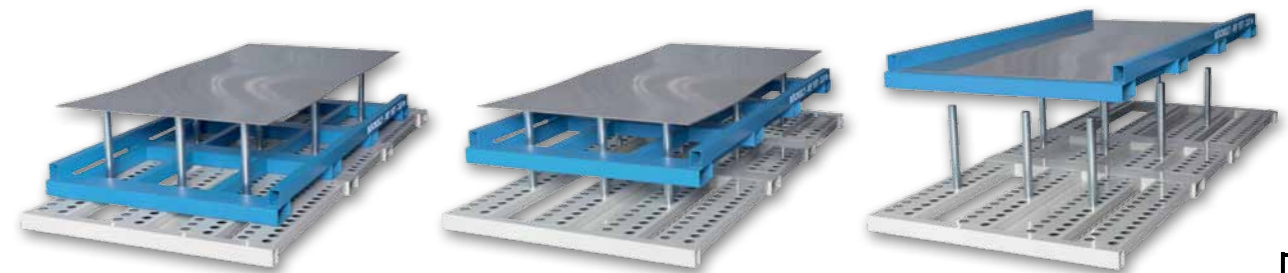

Product video
CASSETTE RACK



Product video
DEPALLETISER

THE LONG GOODS RACK

"WE OPERATE WITH 8 LONG GOODS RACKS. THE DESIGN IS ROCK-SOLID, YET SMOOTH-RUNNING AND OFFERS LOADS OF CAPACITY."

Dennis Janson,
Voß Stainless Steel Distribution

The long goods rack allows for the efficient storage and supply of rod-shaped materials. It is possible to combine different basic systems with a large variety of baskets.

- modular design
- can be operated from one or both sides
- large capacity
- small footprint
- Crane loading possible
- smooth-running basket can be moved with ease
- divisible
- Forklift-accessible versions available



can be operated from both sides



can be operated from one side



selectable loading height

"WHILE ALREADY IN SERVICE FOR MORE THAN 15 YEARS, OUR LONG GOODS RACK IS STILL WORKING FLAWLESSLY."

Dirk Wacker,
HWM Mechanical Engineering

Product video
LONG GOODS RACK



THE EXCHANGE TOWER

Sporting a modular design, the exchange tower is a storage system that can be used for the efficient storage and supply of sheet metal plates or other types of material. The cassette rack can be fitted on top of the custom-designed drawer rack.

Sheet metal plates can be easily removed using an attached easy-rolling crane with lifting apparatus.

- Consistently high operational safety and reliability
- Materials can be swapped within a matter of seconds
- Operation from the front or the rear
- smooth-running drawers
- Option to combine different drawers
- Crane can be mounted on all 4 corners
- Manufactured parts can be returned to storage
- small footprint
- pivoting doors
- optional doors on both sides

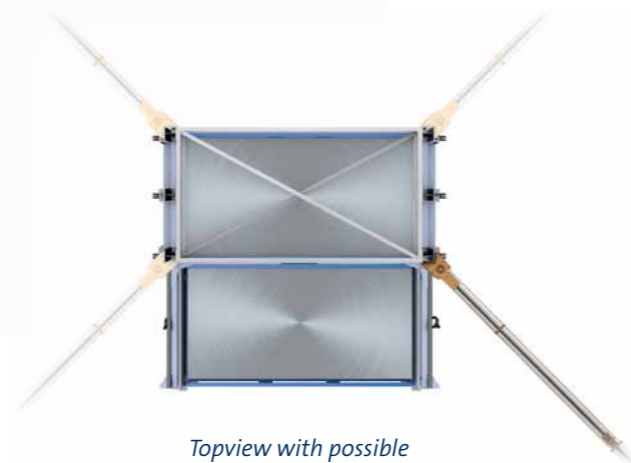

Topview with possible
Crane positions



INTERCHANGEABLE FRAMES:

- direct mounting of system cassettes
- 3-ton bearing capacity
- can be used on either side in the exchange tower

LOAD CARRIERS FOR INTERCHANGEABLE FRAMES:

- Self-supporting design
- Option to use system cassettes of varying sizes
- Supply of material on wooden pallets

COMPACT FRAME:

- direct mounting of metal sheet packages
- Loading by means of crane hangers
- low space requirements in the system
- Custom dimensions, load-bearing capacities and loading heights

"AFTER OUR FIRST EXCHANGE TOWER MET WITH AN OVERWHELMINGLY POSITIVE RESPONSE, WE DECIDED TO INVEST IN A SECOND ONE PLUS ADDITIONAL CASSETTE RACKS."

Alois Spieles,
S&D Sheet Metal Technology

"PRODUCTS MADE BY OTHER MANUFACTURERS SIMPLY CANNOT HOLD A CANDLE TO THE EXCHANGE TOWER."

Thomas Pieé,
Pieé Sheet Metal Processing



Product video
EXCHANGE TOWER EMBEDDED IN A RACK ROW



Product video
EXCHANGE TOWER

SOFTWARE

TRANSPONDER SYSTEM

"THE MANAGEMENT SOFTWARE ALLOWS US TO KEEP CONSTANT TABS ON THE QUANTITY AND POSITION OF OUR MATERIALS THROUGHOUT THE ENTIRE COMPANY."

Matthias Stickel,
Stickel GmbH Sheet Metal Forming

- chaotic warehousing
- visual indication of requested materials
- Light signals allocate the cassette to its target location
- Cassette position is detected automatically
- networking of all systems
- pick by light
- accelerated access
- Prevention of access errors
- protected against damage

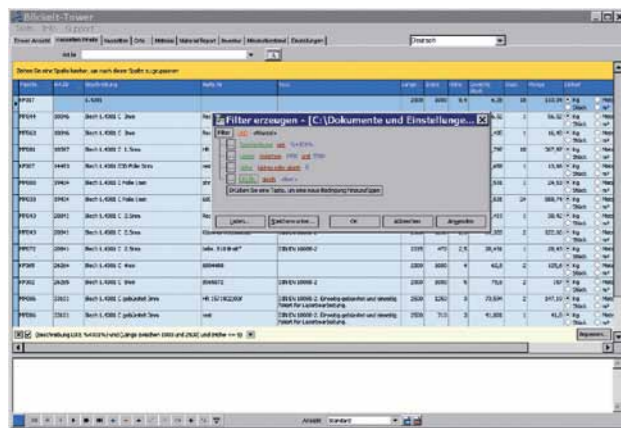

- permanent tracking of material across the company
- Boost in performance
- Support of the purchasing department
- tremendous benefit to all departments
- first-in, first-out
- Storage of inspection certificates
- Evaluation of material movements
- Preservation of resources by surplus management
- configurable
- Export functions
- optional stack terminal with weighing device

"THE BÖCKELT TOWER SERVES US AS A SUPERIOR ALTERNATIVE TO FULLY AUTOMATIC SYSTEMS AS THE INVESTMENT COSTS ASSOCIATED WITH IT ARE COMPARITIVELY LOW."

Heiner Hofmann,
Hofmann GmbH



Product video
SOFTWARE TUTORIAL

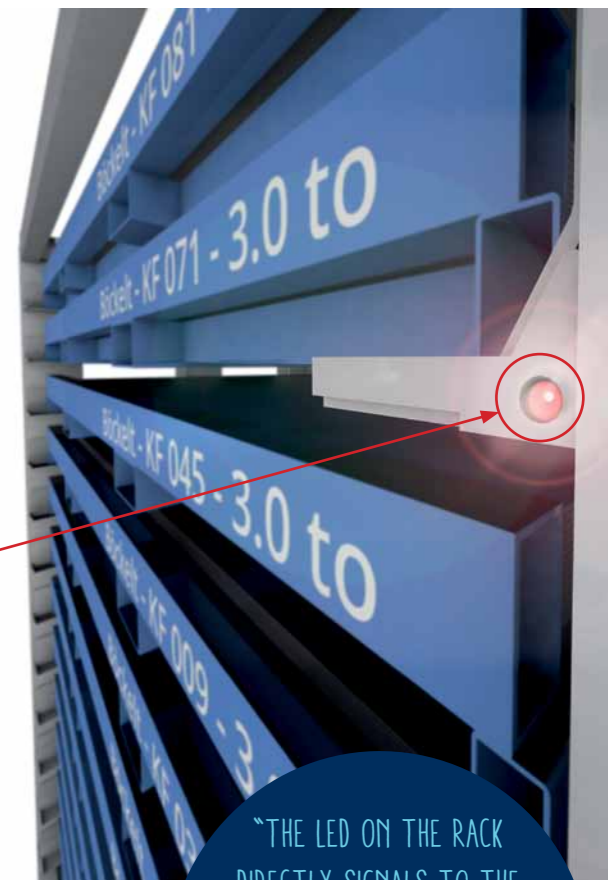

"THE LED ON THE RACK DIRECTLY SIGNALS TO THE FORKLIFT OPERATOR WHICH CASSETTE NEEDS TO BE REMOVED FROM THE RACK."

Thomas Seebold,
Metal Construction Diekmann



Product video
SOFTWARE + TRANSPONDER SYSTEM

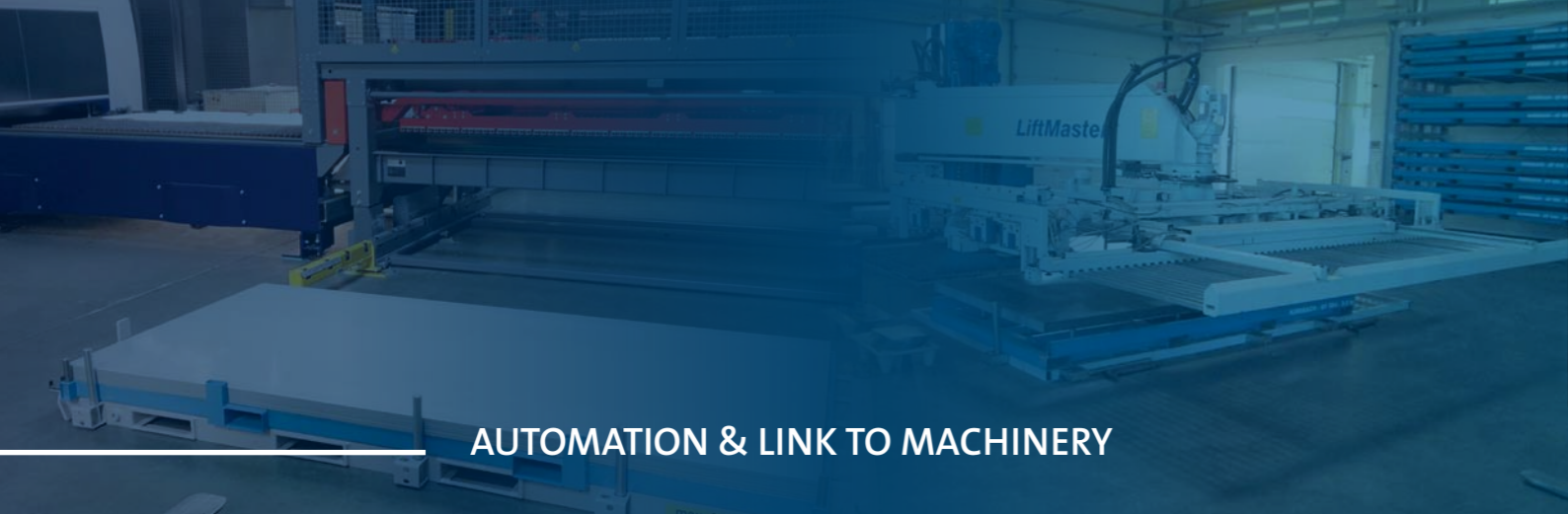

AUTOMATION & LINK TO MACHINERY



OPERATING CONCEPTS



Fully automatic material swap at the processing machine

- autonomous operation
- Cassette can be removed
- compatible with Böckelt cassette rack
- made to match systems of different manufacturers

"THE CUSTOMISED CHARGING EQUIPMENT SUPPLIED BY BÖCKELT HAS MADE A TREMENDOUS DIFFERENCE IN OUR OPERATION."

Rainer Backes,
PUK-GROUP

"WE HAVE BEEN OPERATING WITH A SUCCESSFUL LINK TO THE LASER SYSTEM INCLUDING LOADING SYSTEM FOR 8 YEARS AND COUNTING."

Udo Kirrbach,
Kirrbach GmbH

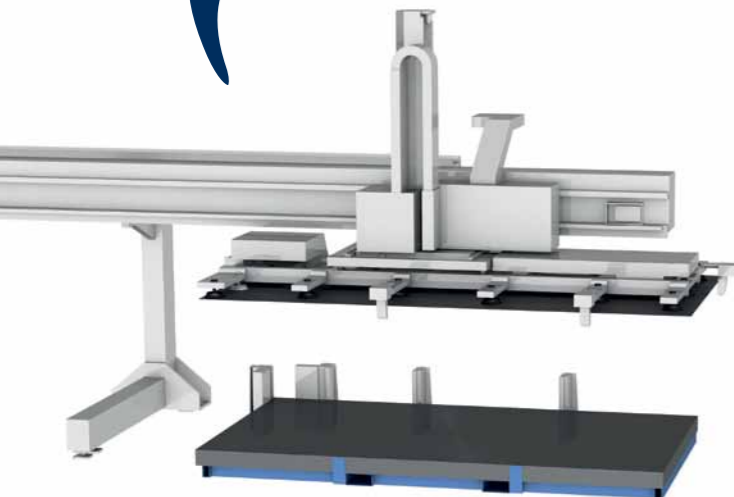

Loading systems remove sheet metal plates directly from the system cassette.

- made to match systems of different manufacturers
- positioning at zero point of the machine
- Swift swap of material

"WE RECEIVED THE CASSETTES IN A FORM THAT OFFERS US THE OPTION TO CONNECT TO A PROCESSING MACHINE – NOW AND IN THE FUTURE."

Thomas Seelig,
Seelig & Co



STACKING CRANE

- outstanding flexibility
- no tracks necessary

"WE CAN USE THE STACKING CRANE TO REMOVE CASSETTES AND MAKE THEM AVAILABLE DIRECTLY AT THE MACHINE."

Robert Mohn,
Mohn & Partner

The BÖCKELT TOWER® storage system can be operated using conventional forklifts and can be combined with a variety of handling systems. We have teamed up with accomplished partners to implement concepts with various degrees of automation.

"THE TOWER IS WORKING VERY WELL, AND IT HAS STREAMLINED OUR PRODUCTION VERY MUCH. WE ARE SATISFIED."

Lassi Otranen,
Reifer Oy



DRIVERLESS TRANSPORT SYSTEM (DTS)

- flexible layout planning
- no rail guide
- Travel around curves possible

Product video
FTS-CONCEPT



INDUSTRY SOLUTIONS

The BÖCKELT TOWER® offers a nearly limitless range of possible applications.

Thanks to its modular design the BÖCKELT TOWER® can also accommodate other types of products aside from flat goods. The dimensions of the rack systems and the cassettes are projected to meet the requirements of your individual application.

The ability to adjust the height of the tray allows us to utilise the capacity of the heavy-duty rack to the full extent.



"THE BÖCKELT TOWER AFFORDED US A MONUMENTAL BOOST IN THE STORAGE DENSITY OF OUR COIL AND RING MATERIALS."

Adrian Kutz,
Köbo-Donghua

"WE HAVE BEEN WORKING WITH THE BÖCKELT TOWER WITH GREAT SUCCESS SINCE 2008 AND USE IT TO STORE RAW METAL SHEETS, CUT PRINTED CIRCUIT BOARDS AND CHAMFERED PARTS."

Heiner Hofmann,
Hofmann GmbH

EXCERPT FROM THE LIST OF REFERENCES



More than 1,000 businesses have been working with our products with great success.



Would you like to see the BÖCKELT TOWER® in action?
We will be happy to name you locations that let you do so.

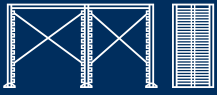

BÖCKELT TOWER®

Flexible storage and logistics systems

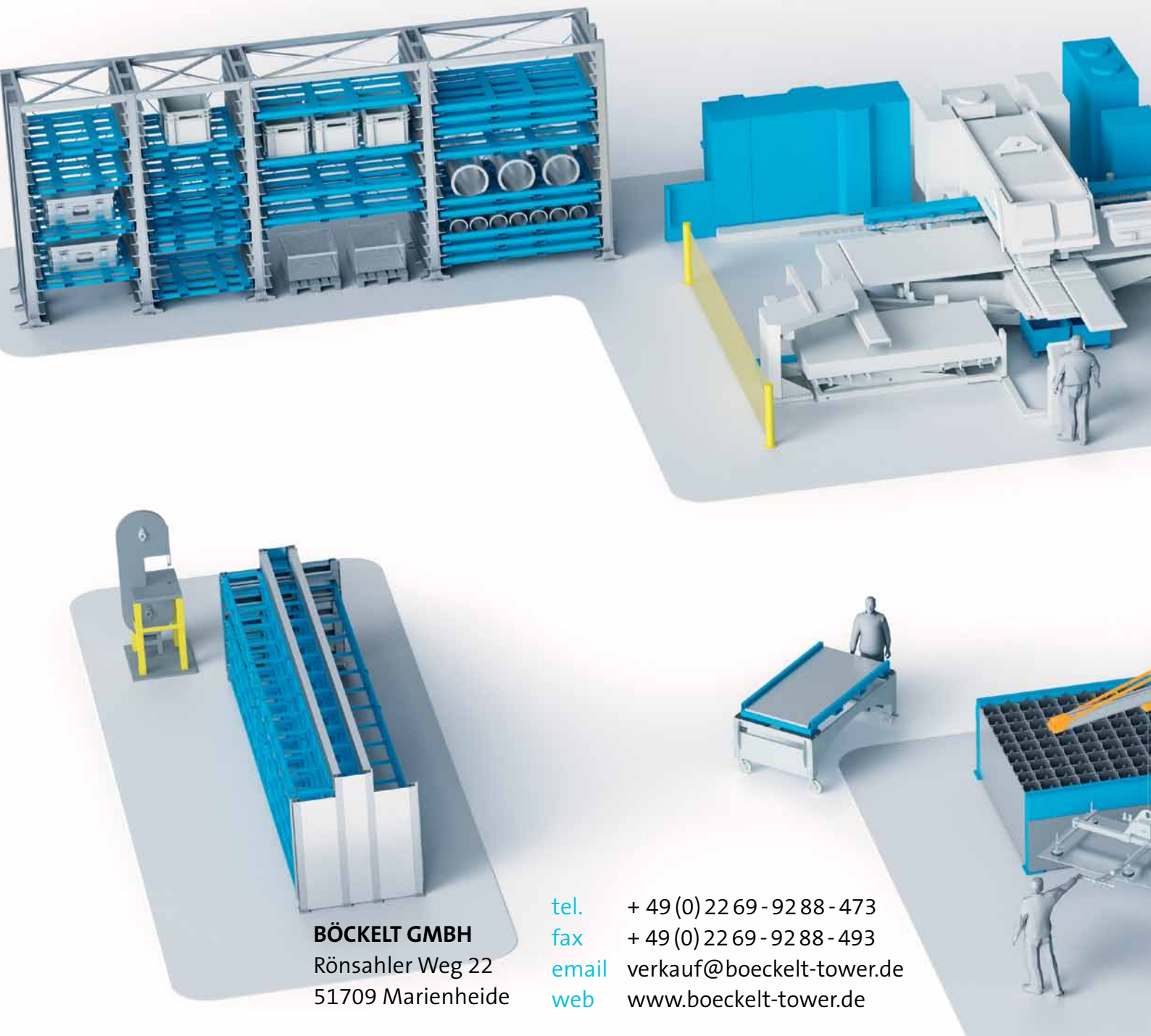

BÖCKELT GMBH
Rönsahler Weg 22
51709 Marienheide

tel. + 49 (0) 22 69 - 92 88 - 473
fax + 49 (0) 22 69 - 92 88 - 493
email verkauf@boeckelt-tower.de
web www.boeckelt-tower.de